



GIORNATE  
ELETTROCHIMICA  
ITALIANA  
17-21 September 2023, Cefalù, Italy

# *Towards Sustainable Energy: Progress in Redox-Free Reverse Electrodialysis with Carbon- Based Capacitive Electrodes*

---

ANNA AIXALÀ-PERELLÓ



Politecnico  
di Torino



ISTITUTO  
ITALIANO DI  
TECNOLOGIA



# Outline

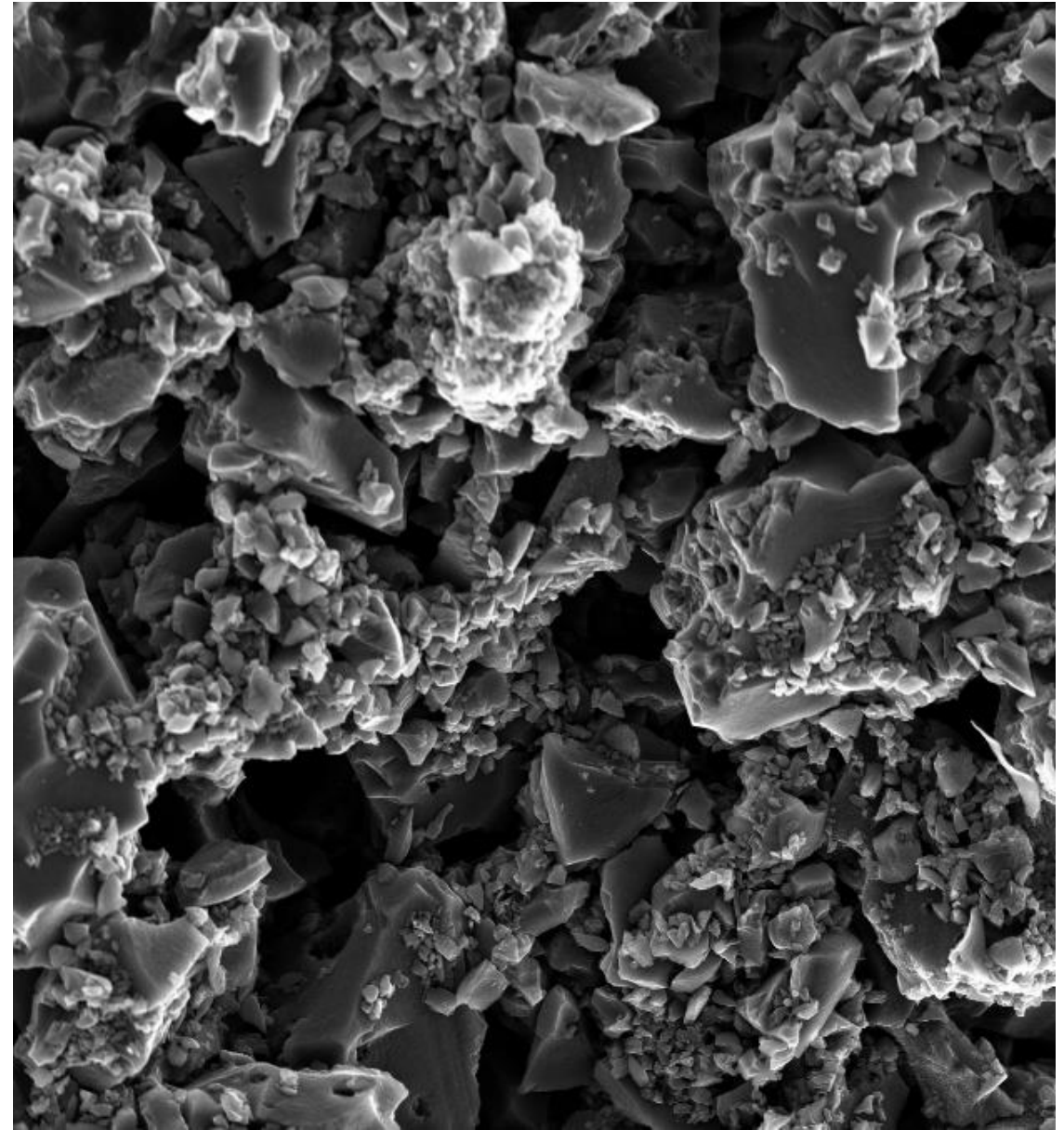
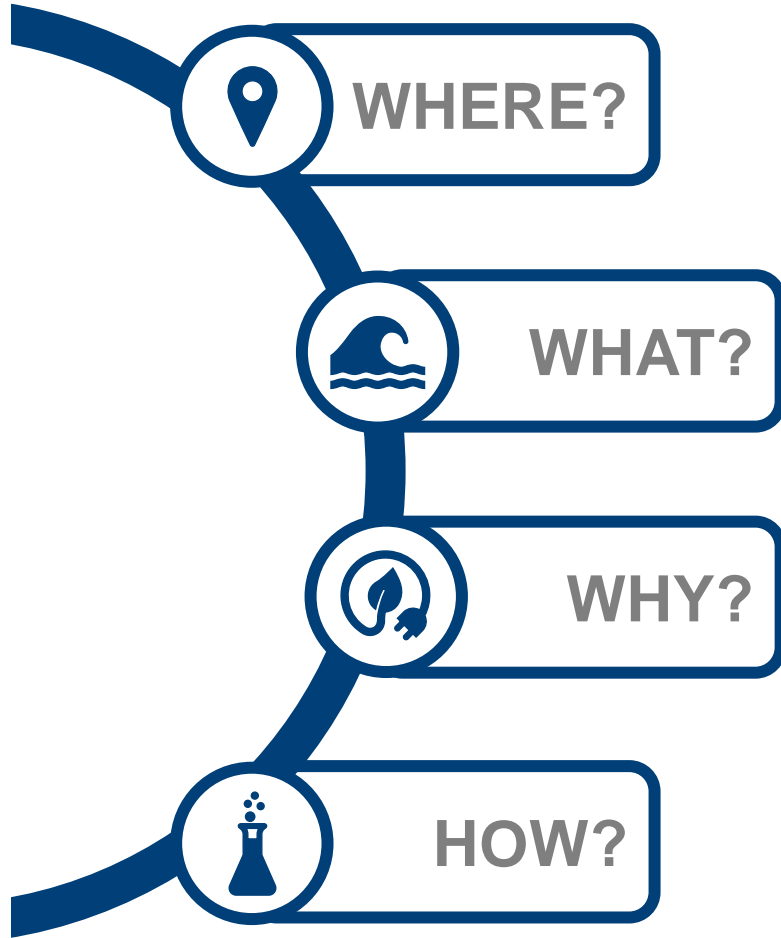

# Outline



# Outline



## REVERSE ELECTRODIALYSIS

Membrane-technology to generate power from mixing waters with different salinity

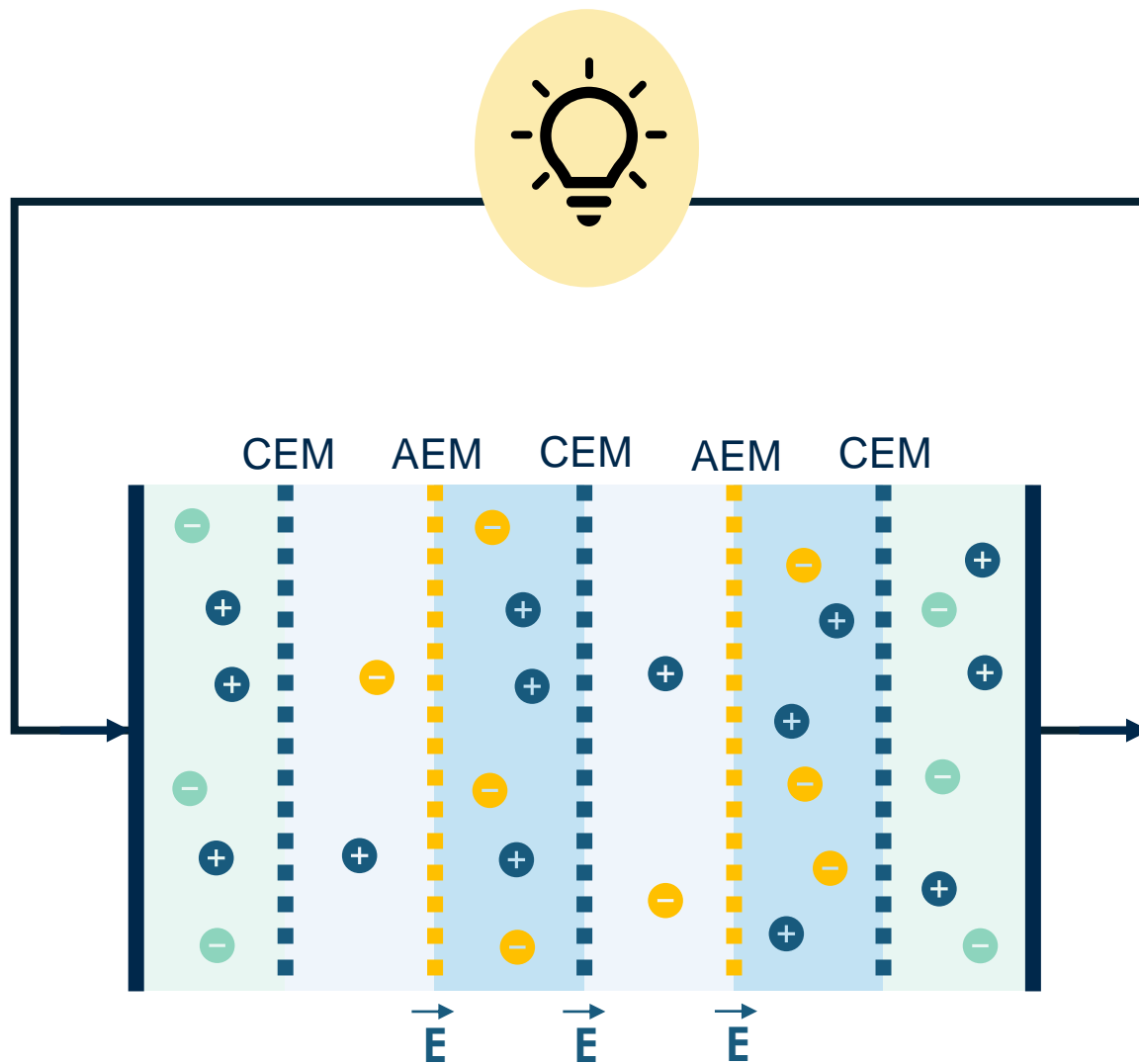

### Redox reactions

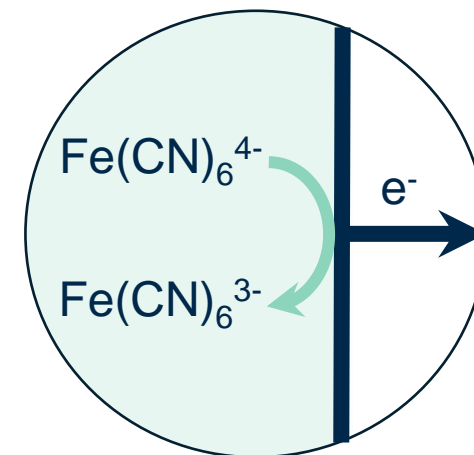

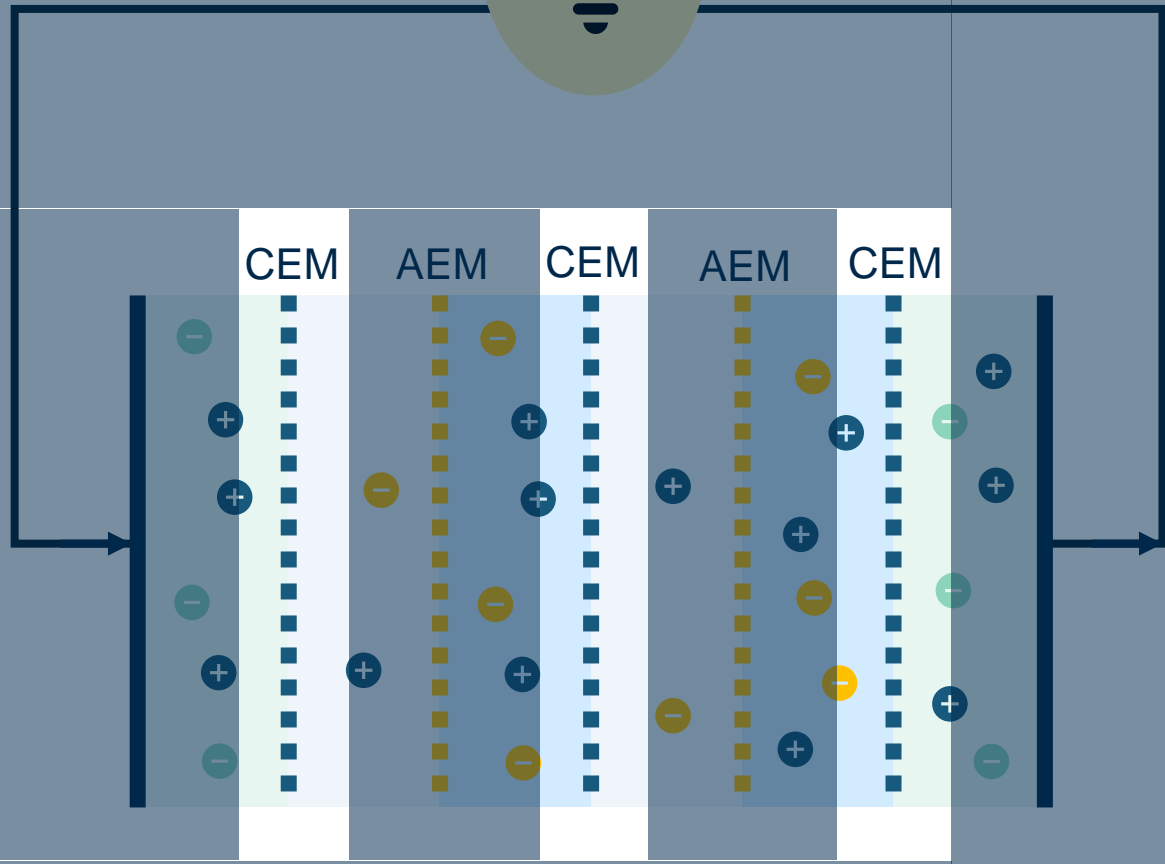

# Graphene Oxide Membranes

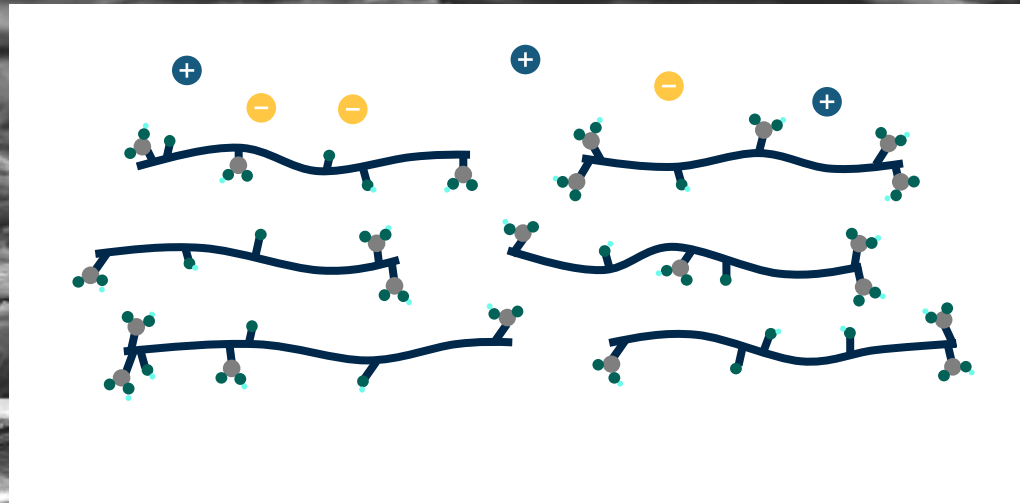

Aixalà-Perelló, A. et al. *npj 2D Mater Appl* **7**, 46 (2023)

# Scalability

## Dr. Blade technique as a scalable fabrication method

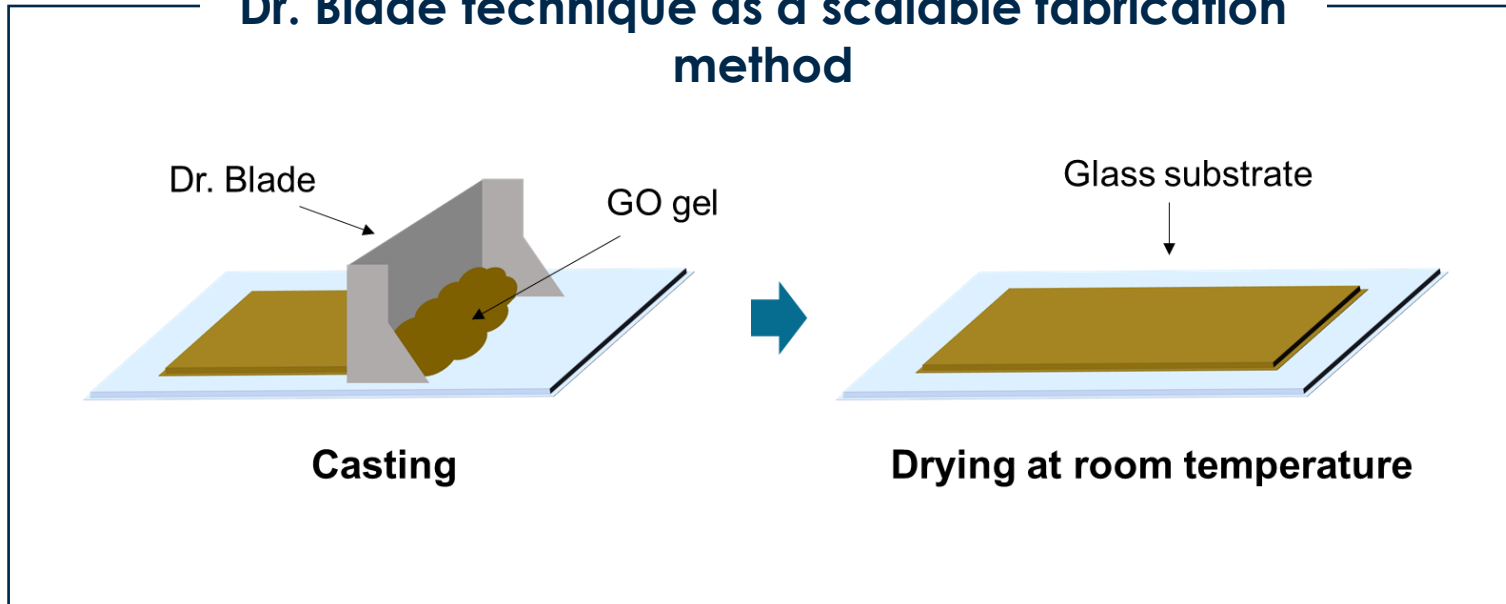

Aixalà-Perelló, A. et al. *npj 2D Mater Appl* **7**, 46 (2023)



# Scalability



Aixalà-Perelló, A. et al. *npj 2D Mater Appl* **7**, 46 (2023)

# Tunable permselectivity and ionic resistance

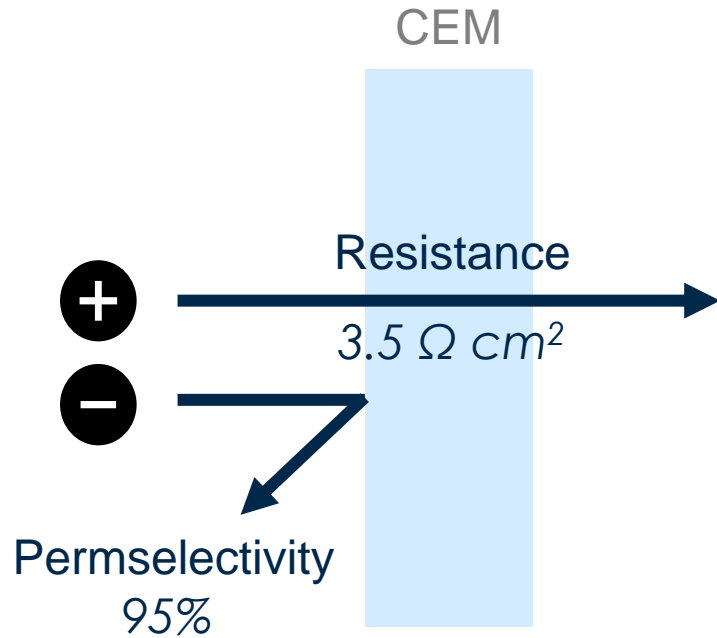

Aixalà-Perelló, A. et al. *npj 2D Mater Appl* **7**, 46 (2023)  
Aixalà-Perelló, A. et al. (2023) (submitted)

## PERMSELECTIVITY

- Thickness
- Lateral size of flakes
- Binders to improve mechanical stability
- UV-light reduction (chemical-free)

## MONOVALENT-SELECTIVE CEM

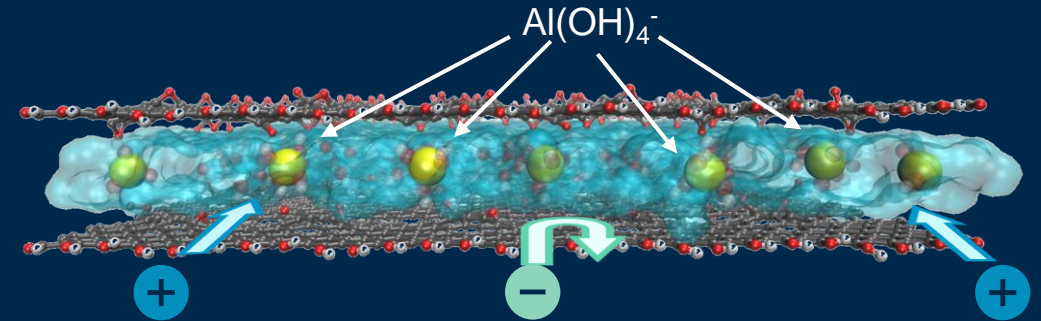

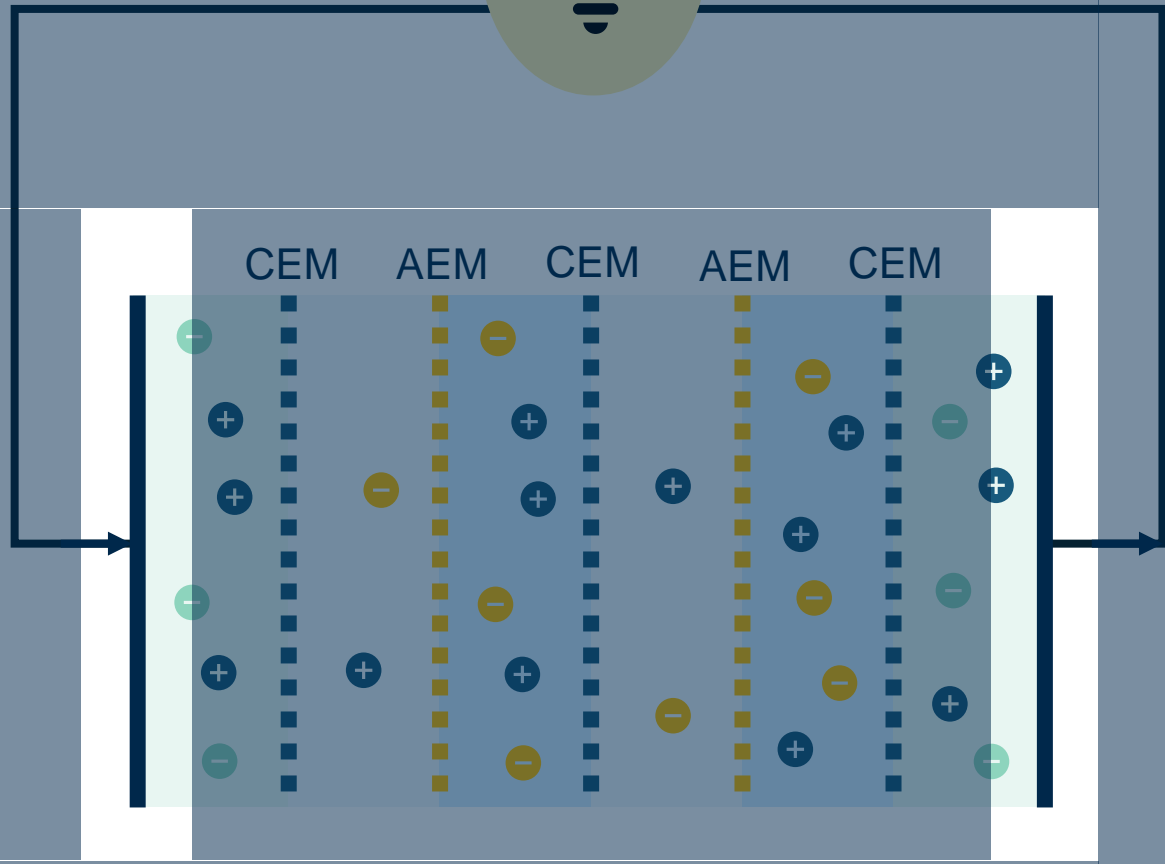

# Outline



✓ Simplify the system

## CAPACITIVE ELECTRODES

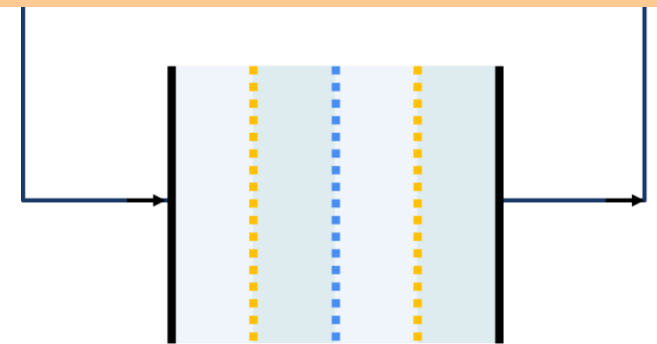
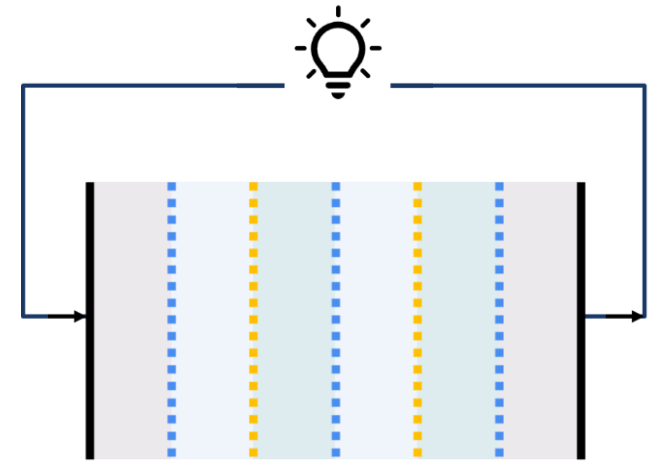

# Carbon-based electrodes

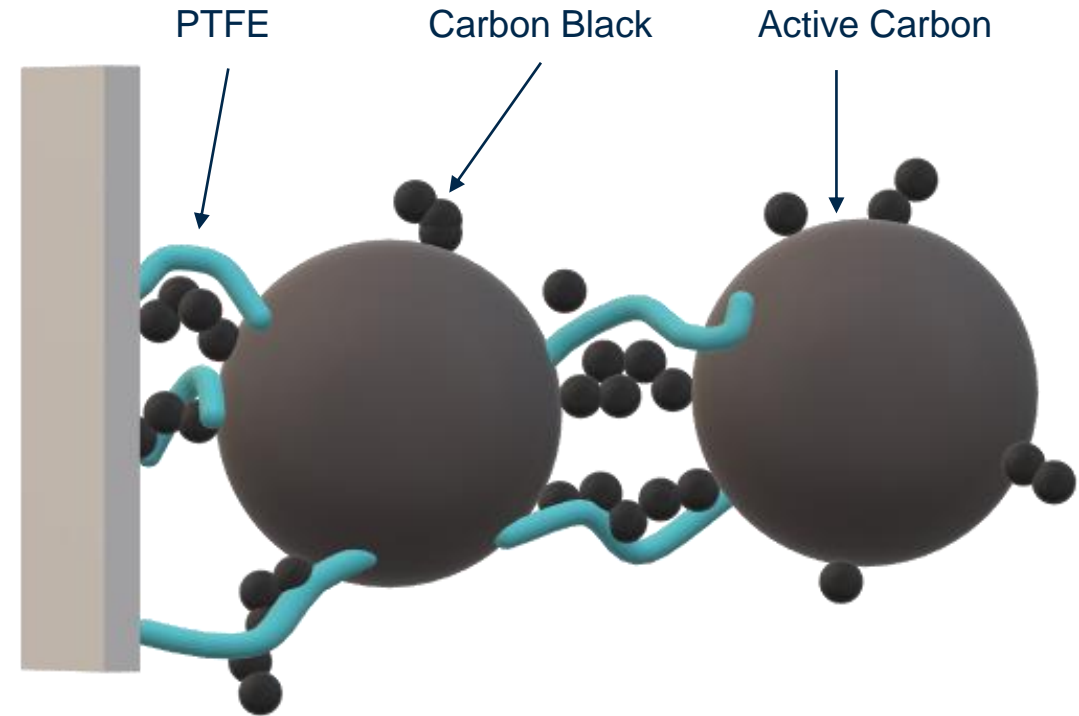

# Carbon-based electrodes

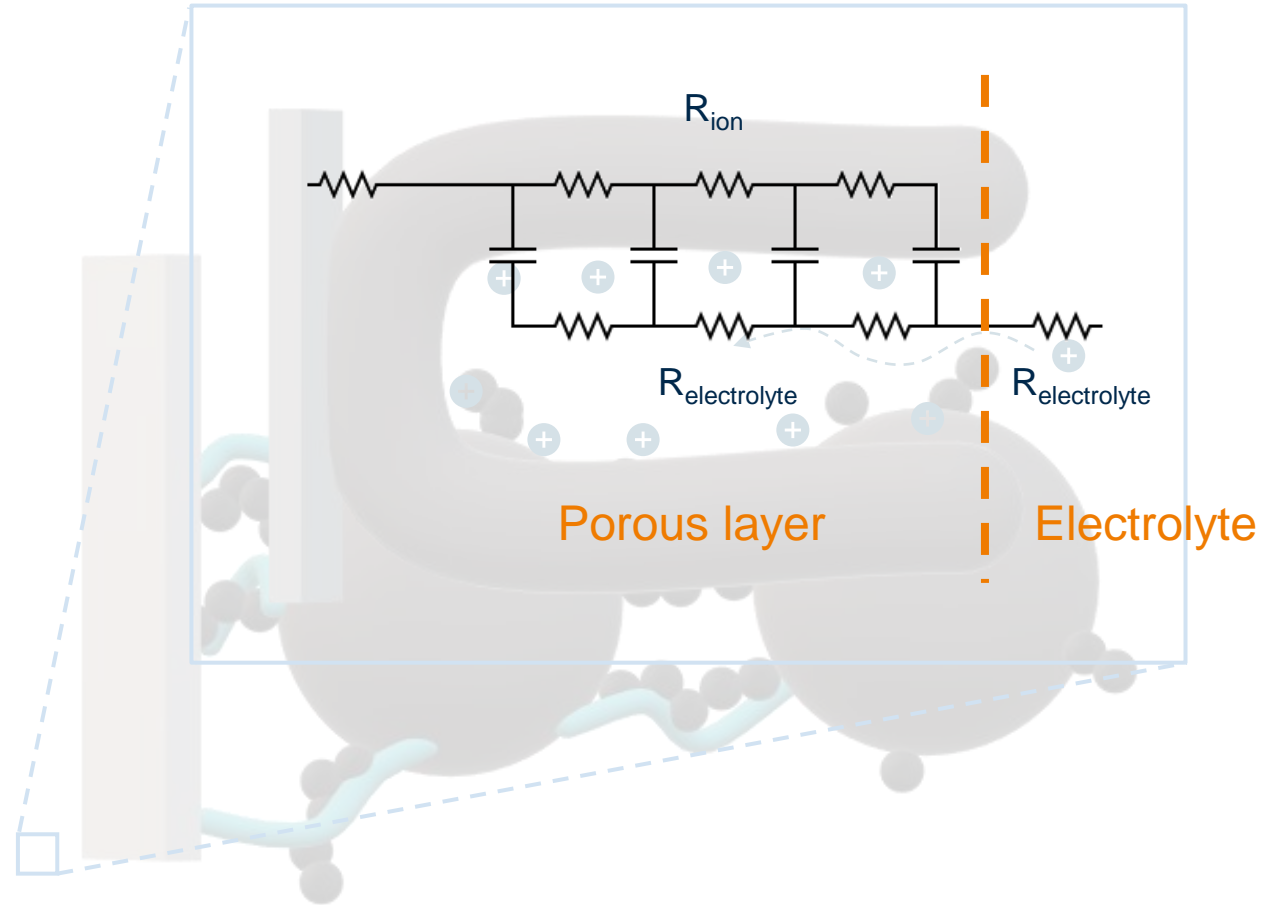

# Alternated Ti grids to reduce overall resistance

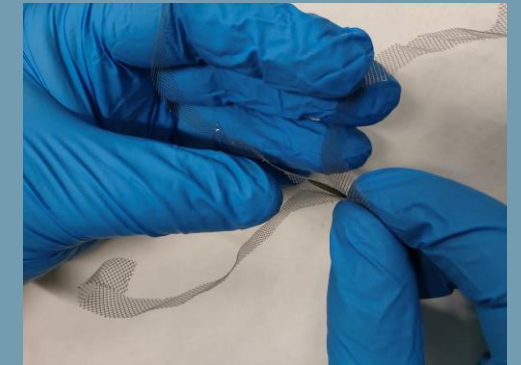
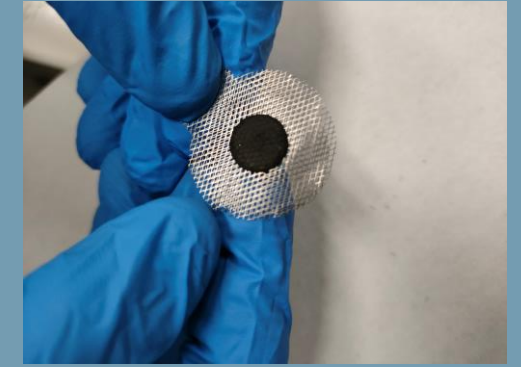
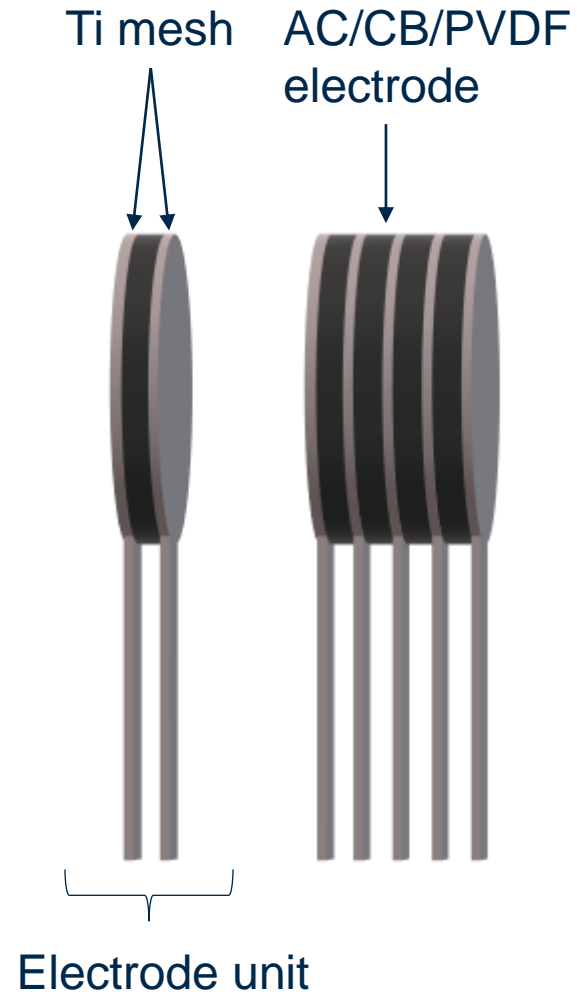
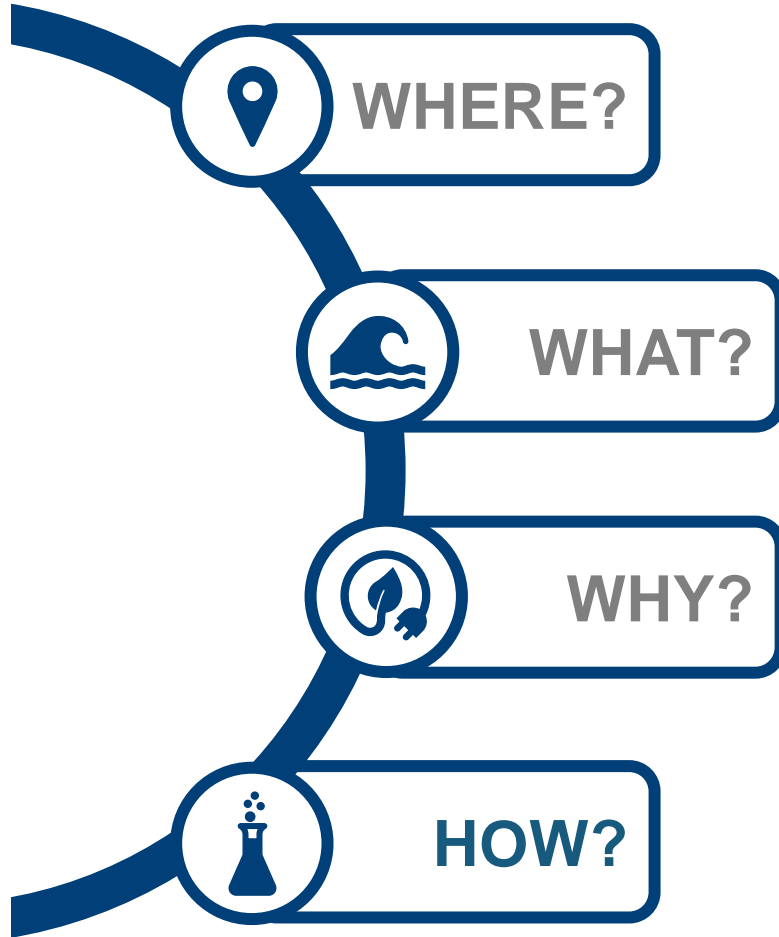

# EIS interpretation

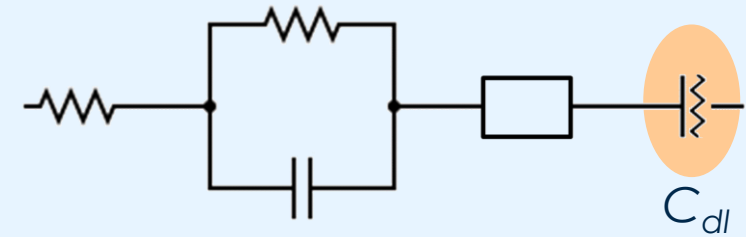
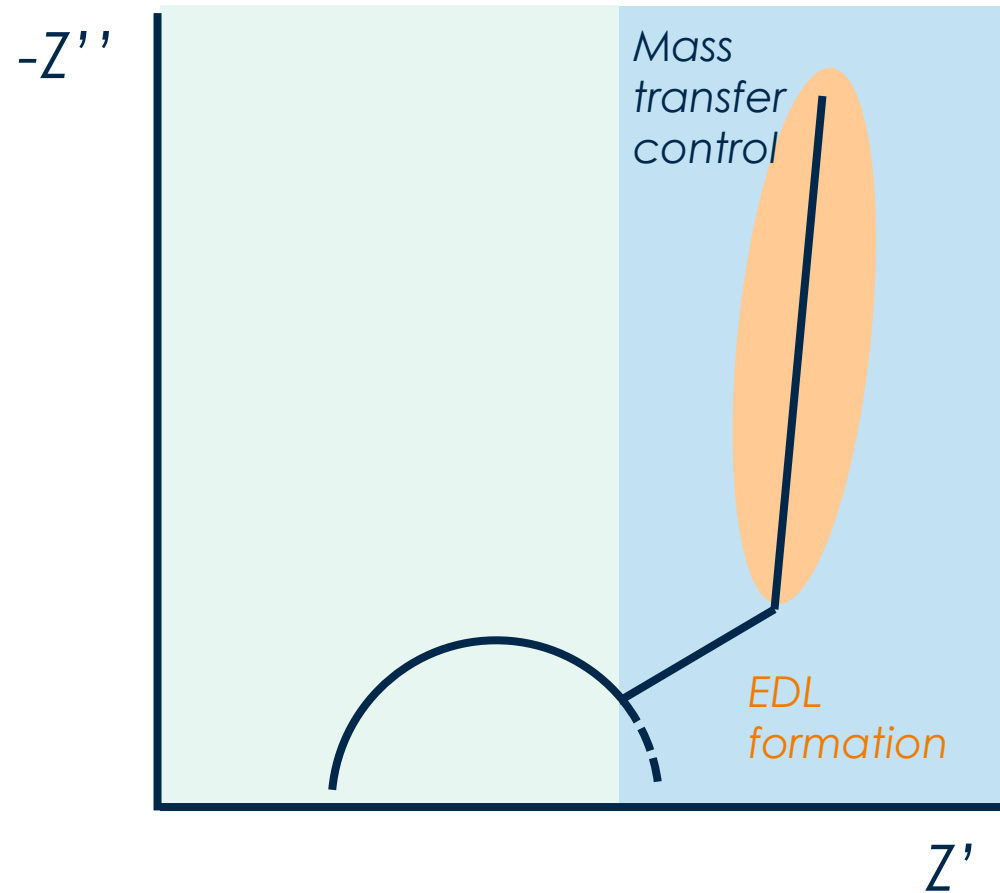

*Electrode properties:*

- ✓ Resistance
- ✓ Capacitance



# $\tau$ (=RC) is dominated by C

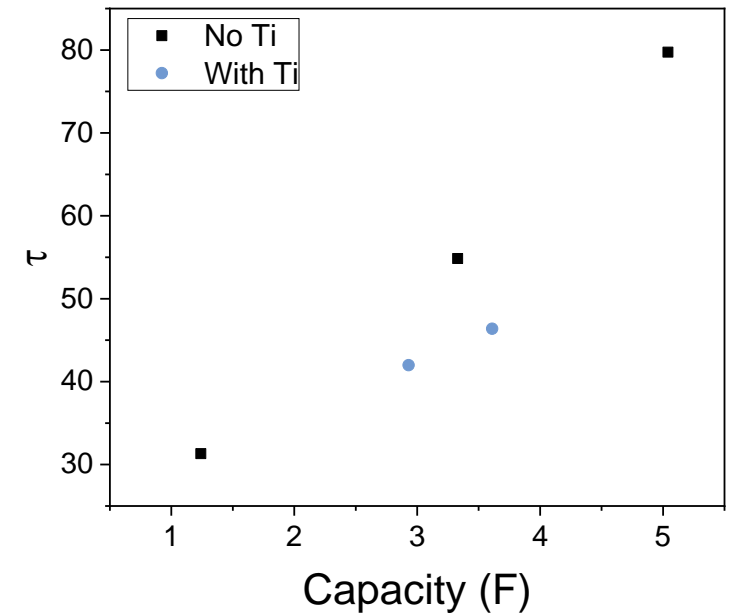
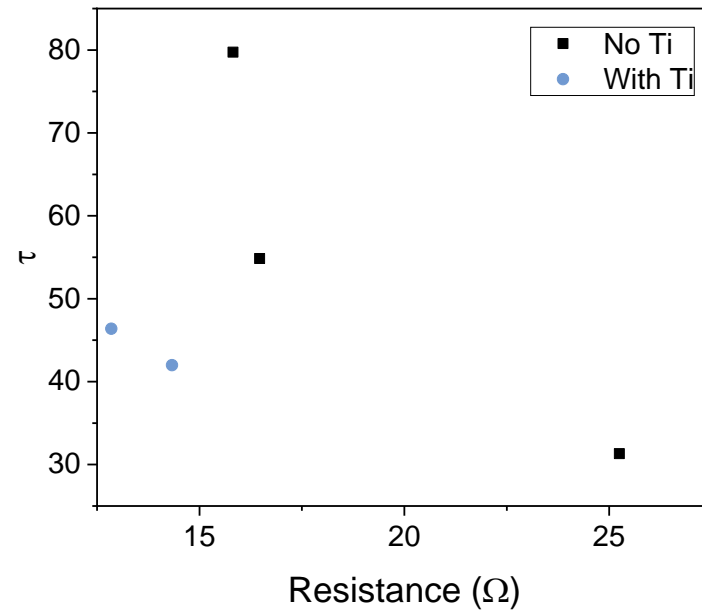
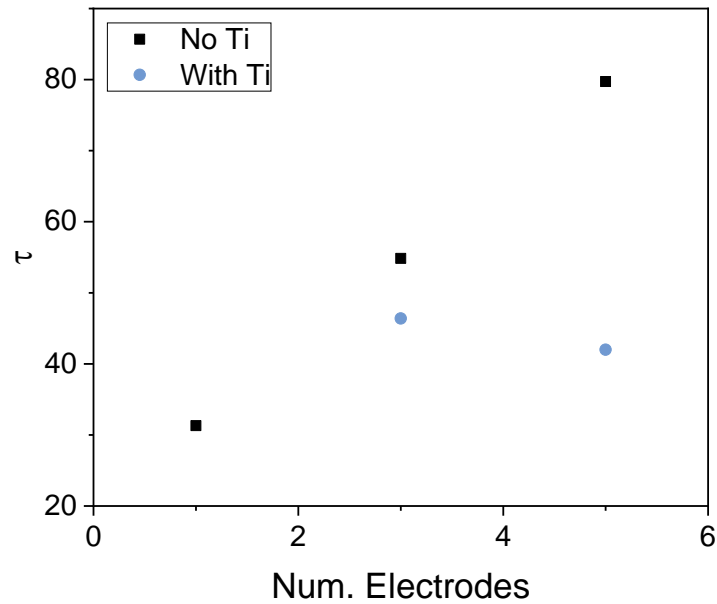

# Controlled electrode polarization

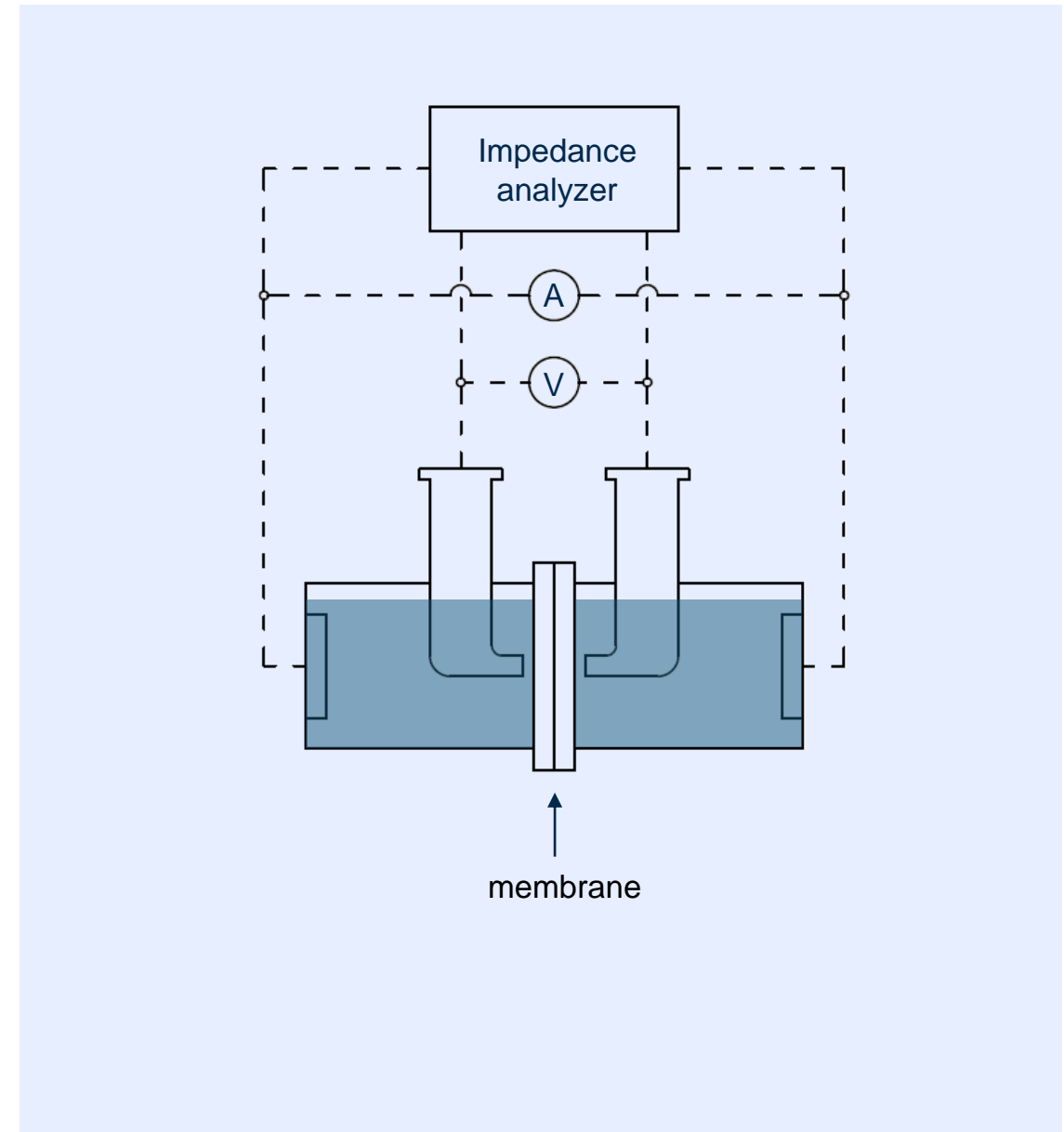
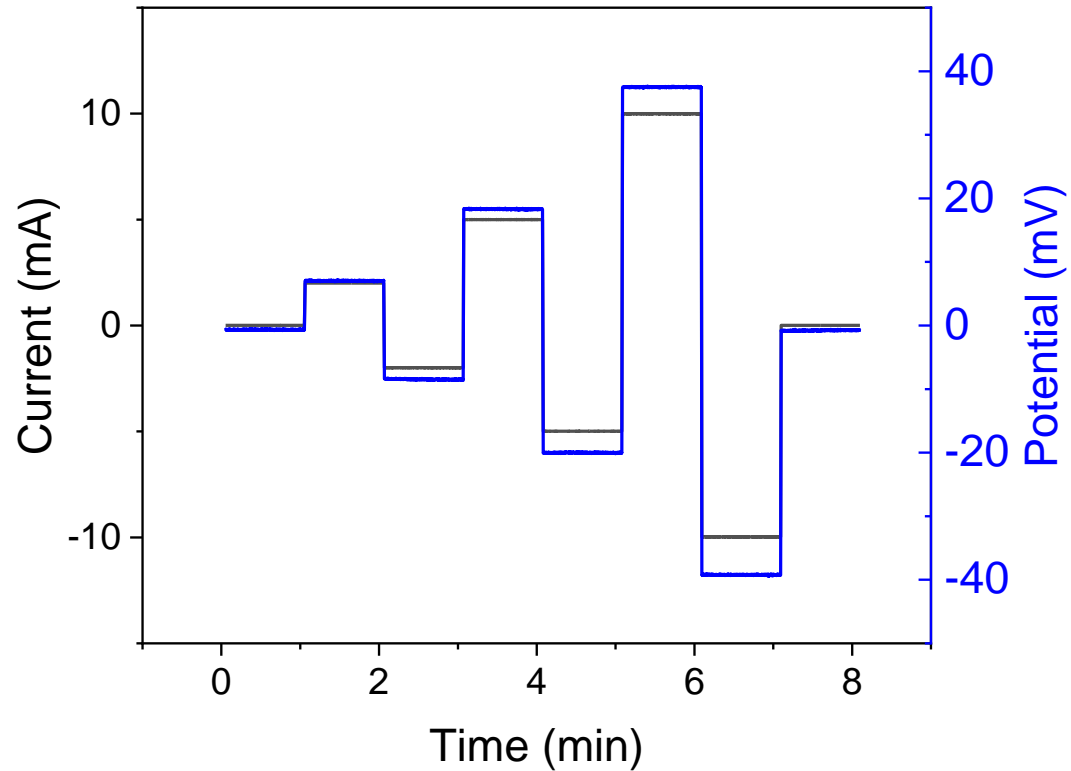

# Controlled electrode polarization

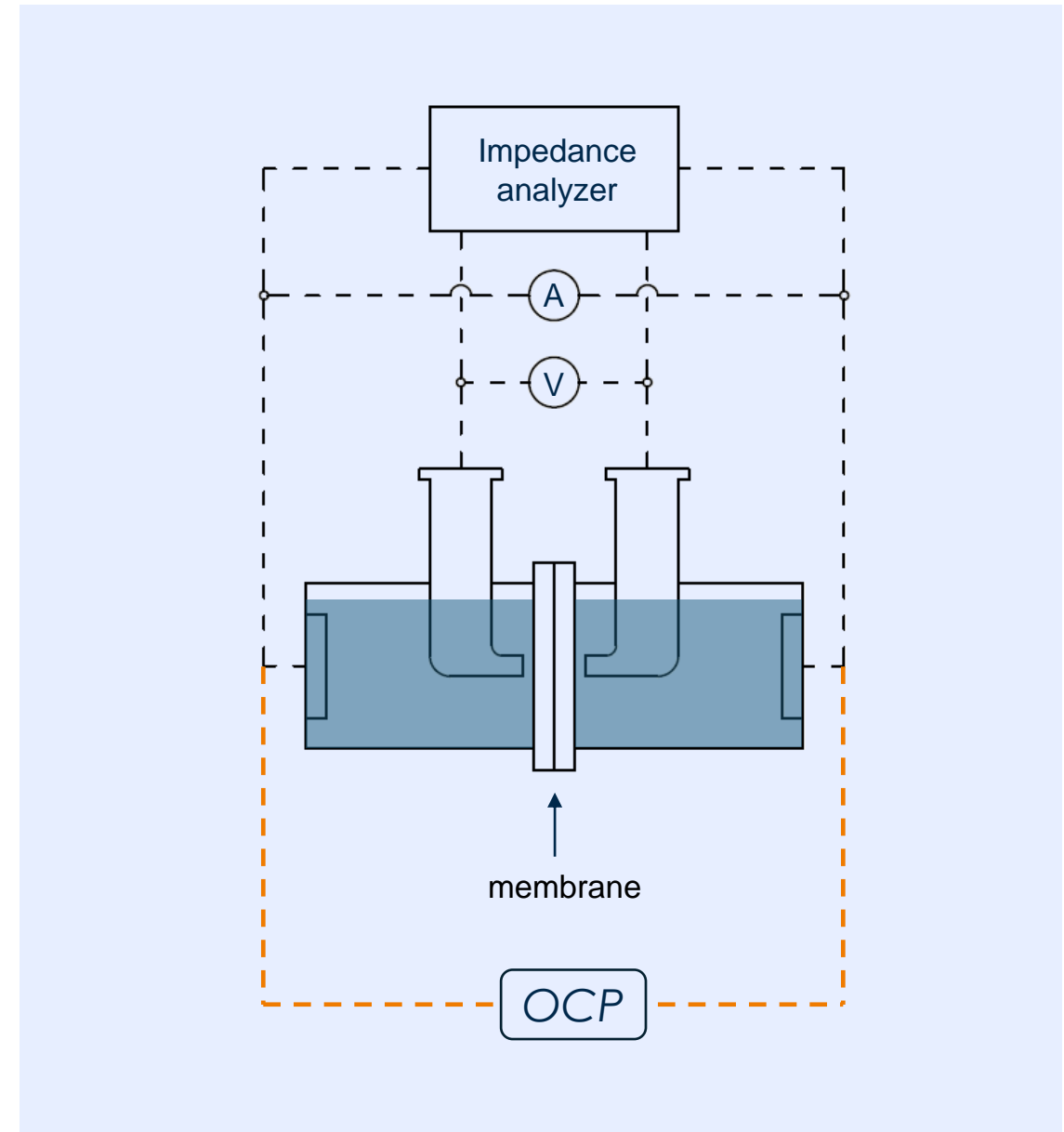
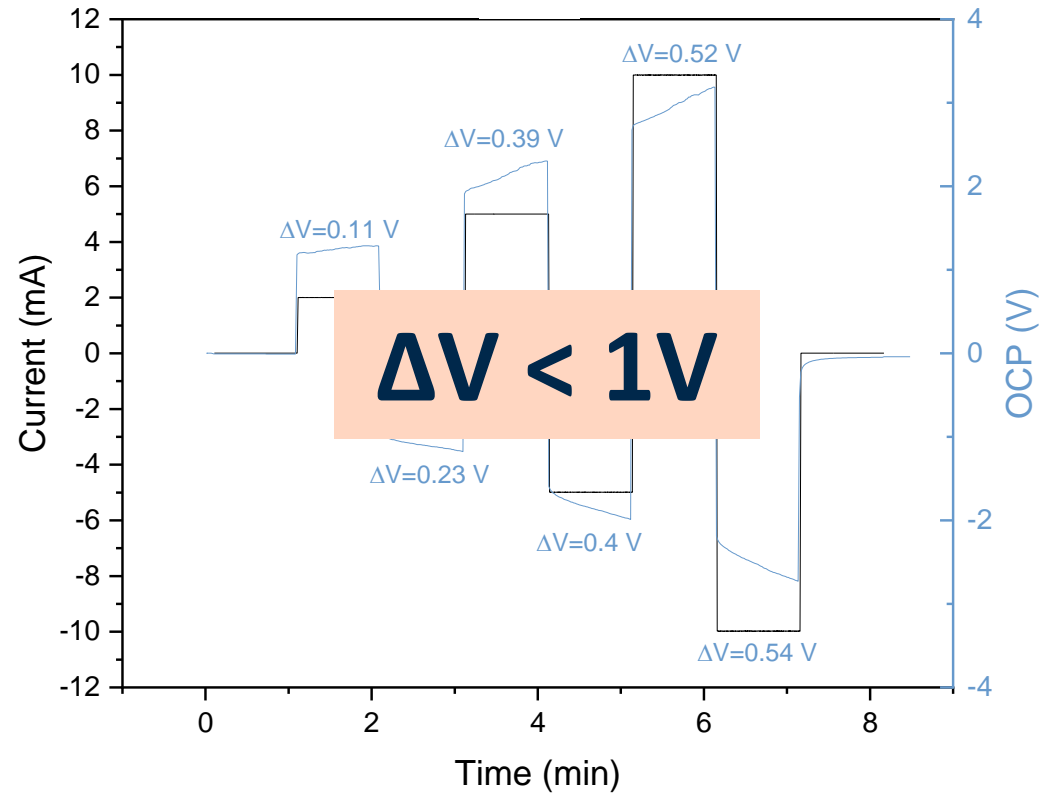

# Final remarks

## MEMBRANES

- *Tunable permselectivity*
- *$\text{Al}(\text{OH})_4^-$  intercalation to enhance membrane's charge*

## CAPACITIVE ELECTRODES

- *Simplified system*
- *Reduced resistance*
- *Controlled electrode polarization*

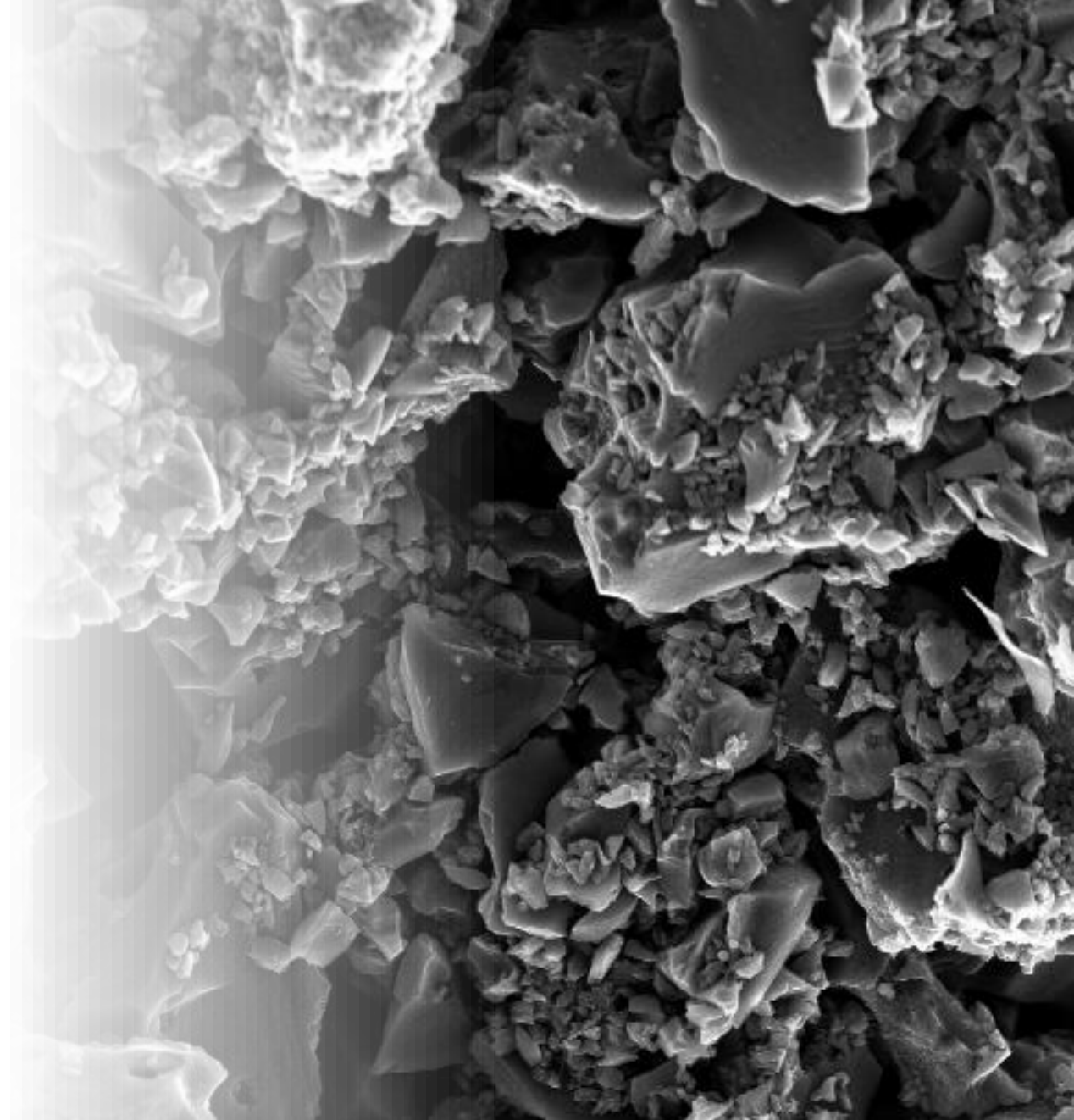

# Don't miss out!



## THANK YOU!



This project has received funding from the European Union's Horizon 2020 research and innovation programme under grant agreement No 958454 



*Alessandro Pedico*  
Poster



*Mara Serrapede*  
Talk: 19<sup>th</sup> Sept at 10.15h  
Poster



*Pietro Zaccagnini*  
Talk: 19<sup>th</sup> Sept at 17.45h  
Poster

Contact me

